

# INSTRUCTION MANUAL

## B/W Vandal-Proof Dome Camera



**CAUTION**  
RISK OF ELECTRIC SHOCK  
DO NOT OPEN



CAUTION : TO REDUCE THE RISK OF ELECTRIC SHOCK,  
DO NOT REMOVE COVER ( OR BACK)  
NOT USE A SERVICEABLE PARTS INSIDE  
REFER SERVICING TO QUALIFIED SERVICE PERSONNEL



This symbol is intended to alert the user to the presence of uninsulated "dangerous voltage" within the product's enclosure that may be of sufficient magnitude to constitute a risk of electric shock to persons.



This symbol is intended to alert the user to the presence of important operating and main tenance instructions in the literature accompanying the appliance.

**WARNING : TO REDUCE THE RISK OF FIRE OR ELECTRIC SHOCK  
DO NOT EXPOSE THIS APPLIANCE TO RAIN OR MOISTURE**

### Dimensions

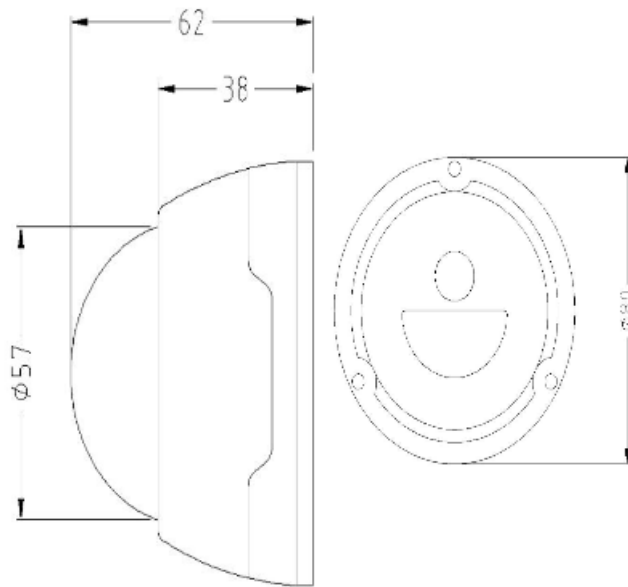

### Connection

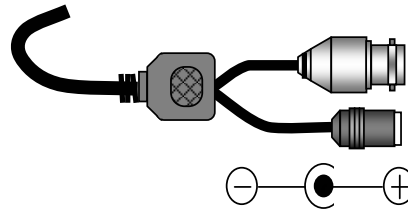

### Specification



**CAUTION : Please Use Regulated Power Supply  
12VDC 300mA**

		CD31	
TV SYSTEM		EAI	CCIR
NO. OF PIXELS	H	510	500
	V	492	582
SCANNING FREQUENCY	H	15.734 KHz	15.625 KHz
	V	59.94 Hz	50 Hz
SHUTTER SPEED		1/60 ~ 1/100,000 sec	1/50 ~ 1/100,000 sec
IMAGE PICK-UP DEVICE		1/3" IT B / W CCD Image Sensor	
SCANNING SYSTEM		2:1 Interlaced	
HORIZONTAL RESOLUTION		400 TV Lines	
S/N RATIO (AGC off)		More than 46 dB	
MIN. SENSITIVITY		0.1 Lux - at F : 1.4 / 50 IRE	
GAMMA CORRECTION		0.45 Approx	
VIDEO OUTPUT		Composite Video 1.0Vp-p/75ohm	
BURST LEVEL		40 IRE	
LENS		Fixed 3.6mm Lens	
POWER SOURCE		12VDC , 300mA Regulated Power Supply	
POWER CONSUMPTION		Max 2Watt	
OPERATING TEMP.		-10°C - +50°C	
DIMENSIONS / MM		80(W) X 62(H)	
CABLE		BNC / DC Jack cable	
WEIGHT		230g	