



# BLACK

## High Performance Indoor/Outdoor Color CCTV Dome Camera User Manual

Products: BLK-CCD203VS, BLK-CCD205VH, BLK-CPD206VH,  
BLK-CCD223VS, BLK-CCD225VH, BLK-CPD226VH



Please read this manual before using your camera, and always follow the instructions for safety and proper use. Save this manual for future reference.



*Changes or modifications not expressly approved by the manufacturer could void the user's authority to operate the equipment.*



*To prevent electric shock and risk of fire hazards:  
Use a power source that is within specification only.  
Do NOT expose this appliance to rain or moisture.*

#### REGULATORY NOTICE

This device complies with Part 15 of the FCC Rules. Operation is subject to the following two conditions:

- (1) This device may not cause harmful interference, and
- (2) This device must accept any interference received, including interference that may cause undesired operation.

This equipment has been tested and found to comply with the limits for a Class A digital device, pursuant to Part 15 of the FCC Rules. These limits are designed to provide reasonable protection against harmful interference in a residential installation.

This equipment generates, uses, and can radiate radio frequency energy and, if not installed and use in accordance with the instructions, may cause harmful interference to radio communications.

Operation of this equipment in a residential area is likely to cause interference, in which case the user will be required to correct the interference at his own expense.

#### LEGAL NOTICE

DIGIOP products are designed to meet safety and performance standards with the use of specific DIGIOP authorized accessories. DIGIOP disclaims liability associated with the use of non-DIGIOP authorized accessories.

The recording, transmission, or broadcast of any person's voice without their consent or a court order is strictly prohibited by law.

DIGIOP makes no representations concerning the legality of certain product applications such as the making, transmission, or recording of video and/or audio signals of others without their knowledge and/or consent. We encourage you to check and comply with all applicable local, state, and federal laws and regulations before engaging in any form of surveillance or any transmission of radio frequencies.

Other trademarks and trade names may be used in this document to refer to either the entities claiming the marks and names or their products. DIGIOP, Inc. disclaims any proprietary interest in trademarks and trade names other than its own.

No part of this document may be reproduced or distributed in any form or by any means without the express written permission of DIGIOP, Inc.

© 2011 by DIGIOP, Inc. All Rights Reserved.

3850 Priority Way South Drive, Suite 200, Indianapolis, IN 46240  
Sales/Support: 1.877.972.2522



# Table of Contents

	Precautions .....	iv
<b>SECTION 1</b>	<b>Introduction .....</b>	<b>1</b>
	Features .....	1
	1.1 Cameras with a vandalproof enclosure .....	2
	1.2 Cameras with a plastic enclosure .....	3
<b>SECTION 2</b>	<b>Installation .....</b>	<b>5</b>
	2.1 General Guidelines .....	5
	2.2 Vandalproof camera mounting .....	6
	2.3 Plastic camera mounting .....	7
	2.4 Camera adjustments .....	7
<b>SECTION 3</b>	<b>Software Setup .....</b>	<b>9</b>
	3.1 LENS .....	9
	3.2 EXPOSURE .....	9
	3.3 WHITE BALANCE .....	10
	3.4 BACKLIGHT .....	11
	3.5 DAY&NIGHT .....	12
	3.6 DPC (Dead Pixel Compensation) .....	13
	3.7 SPECIAL .....	13
<b>SECTION 4</b>	<b>Specifications .....</b>	<b>17</b>
<b>APPENDIX A</b>	<b>Troubleshooting .....</b>	<b>19</b>
<b>APPENDIX B</b>	<b>Camera Dimensions .....</b>	<b>20</b>
	Camera with vandalproof housing .....	20
	Camera with plastic housing .....	20



## PRECAUTIONS

### Precautions

**Do not install the camera in extreme temperature conditions.** Use the camera in environments where temperature is between 14°F and 122°F. Ensure adequate ventilation.

**Do not install or use the camera in an environment where the humidity is high.** It can degrade the image quality.

**Do not install the camera under unstable lighting conditions.** Severe lighting changes or flicker can cause the camera to work improperly.

**Never use the camera close to a gas or oil leak.** These chemicals can damage the camera.

**Do not drop the camera or subject it to physical shocks.** These can cause malfunctions to occur.

**Never point the camera at intense light.** Smear or blooming may occur, and it can damage the CCD.

**Do not expose an indoor camera to rain or spill liquids on it.** If it gets wet, wipe it dry immediately. Liquids can contain minerals that corrode electronic components.

**Check the power source** to ensure that it is within specifications before connecting it to the camera.



## SECTION 1

# Introduction

DIGIOP Black high performance indoor/outdoor CCTV dome cameras feature a very high resolution Sony® CCD sensor providing 600 TVL, with a 2.8 – 11 mm lens, a digital wide dynamic range, dual voltage range support (24 VAC, 12 VDC), and on-screen display (OSD) for control and setup. These cameras are available with or without an IR array, and in either a durable plastic or vandalproof enclosure.

### Features

- Wall or ceiling mounting through 3-axis camera bracket
- Safety strap keeps dome cover attached while making adjustments
- 1/3" Sony Super HAD CCD II: 410K pixels
- High resolution 600 TV Lines
- Day or day/night operation (ICR)
- Vari-focal lens 2.8~11mm
- Digital wide dynamic range
- Digital noise reduction
- Privacy mask function
- On screen display (OSD)
- Motion detection
- Parking line
- Backlight Compensation (BLC) and High Light Compensation (HLC)
- IR Smart features

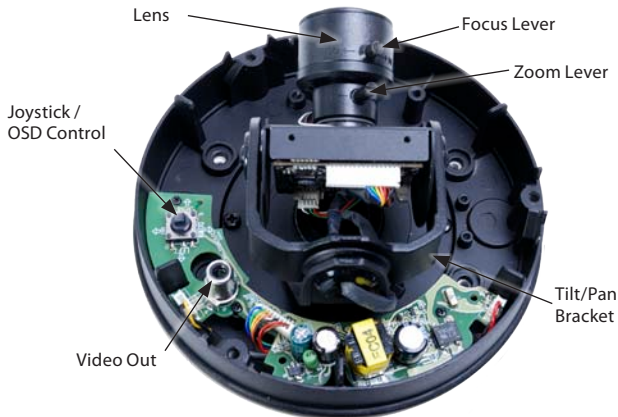

*Internal Components - Cameras Without IR Array*



## SECTION 1: INTRODUCTION

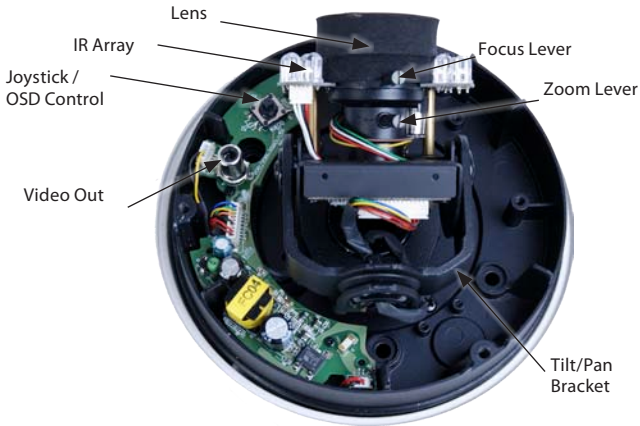

*Internal Components - Cameras With IR*

### 1.1 Cameras with a vandalproof enclosure

Vandalproof cameras are IP67 rated and include a rugged die-cast aluminum enclosure. They are flush surface mountable using the mount adaptor box supplied.

#### 1.1.1 What's in the box

Your camera includes the following:

- Security tool
- Machine screws (4)
- Mounting cap
- Mounting screws (4)
- L-wrench
- User manual
- Dome bracket (optional)

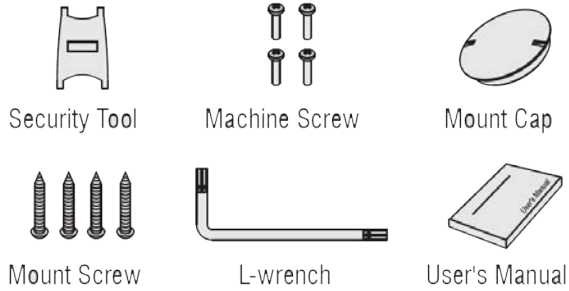

*What's in the box*

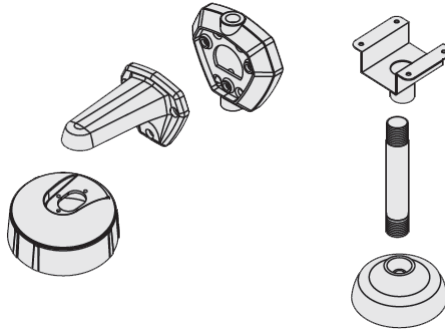

*Optional dome bracket for wall and ceiling mounting*

## 1.1.2 What you need

To install the camera you will need:

- 12 VDC or 24 VAC power source
- Tools for mounting the camera

## 1.2 Cameras with a plastic enclosure

### 1.2.1 What's in the box

Your camera includes the following:



## SECTION 1: INTRODUCTION

- Mounting screws (4)
- L-wrench
- User manual
- Dome bracket (optional)



Mount Screw



L-wrench

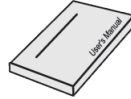

User's Manual

*What's in the box*



*Optional dome bracket*



## SECTION 2 Installation

### 2.1 General Guidelines

- **Outdoor installations:** Use the rubber rings included with the machine screws (4) to ensure that the unit is sealed properly.

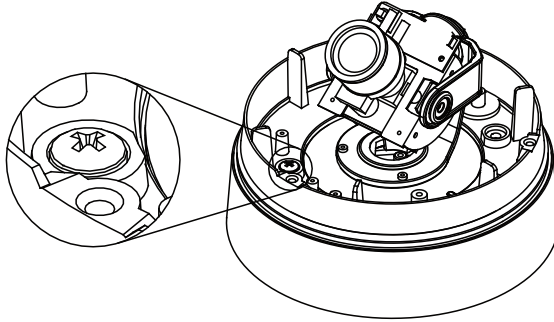

- **Dome/window care:** Handle the dome carefully to prevent scratching. If a scratch appears over the lens, adjust the dome window to move the scratch out of view.



#### CAUTION

*Keep dome cover and camera lens clean. To avoid smearing, do not expose the camera lens to a strong light source such as the sun or spot lights.*

- **Monitor impedance:** Set the monitor impedance switch to 75Ω.
- **Power supply:** To avoid fire or shock hazard, use only a UL listed power supply.
- **Camera drop cable:** The camera drop cable includes two connectors:
  - **Power connector** (black with green terminal adapter) – The connector is non-polarized. Use AC24V power source (AC24V 1A adapter) or DC 12V power source (DC12V 1A adapter).
  - **Video coax connector** (BNC, yellow) – for transmission of the video signal across coax (75Ω) cable.



## SECTION 2: INSTALLATION



Power Connector

Video Coax Connector

### 2.1.1 What you need

To install the camera you will need:

- 12 VDC or 24 VAC power source
- Tools for mounting the camera

## 2.2 Vandalproof camera mounting

The camera can be installed on a junction box or directly to a wall or ceiling.

1. Attach the surface mount bracket to the ceiling or wall using four (4) mounting screws.
2. Connect the dome base to the surface mount bracket using the screws with rubber rings provided.
3. Route the power and video cables to the camera location and attach them to the camera drop cable (see **General guidelines** above).
4. Attach the dome base to the surface mount bracket using the four machine screws provided.

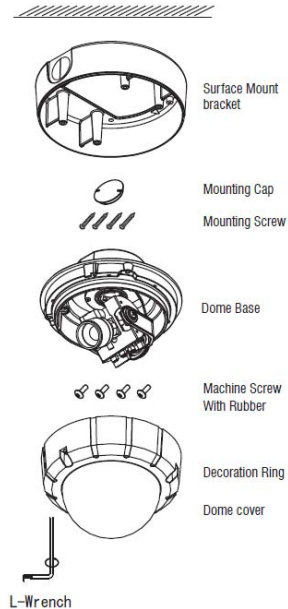



## 2.3 Plastic camera mounting

1. Connect the dome base to the mounting surface using four (4) screws.
2. Route the power and video cables to the camera location and attach them to the camera drop cable (see **General guidelines** above).

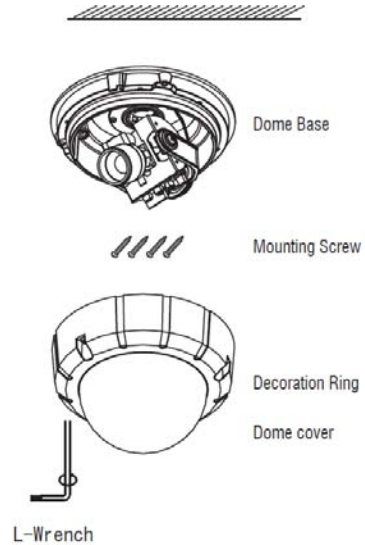

## 2.4 Camera adjustments

1. Attach a video setup monitor to the yellow RCA (EXTRA VIDEO OUT) connector inside the camera assembly, or setup a remote monitor for viewing video from the camera.
2. Power on the camera and video monitor.
3. While observing video from the camera, adjust the pan/tilt swivel and PCB bracket to aim the camera in the preferred direction.



## SECTION 2: INSTALLATION

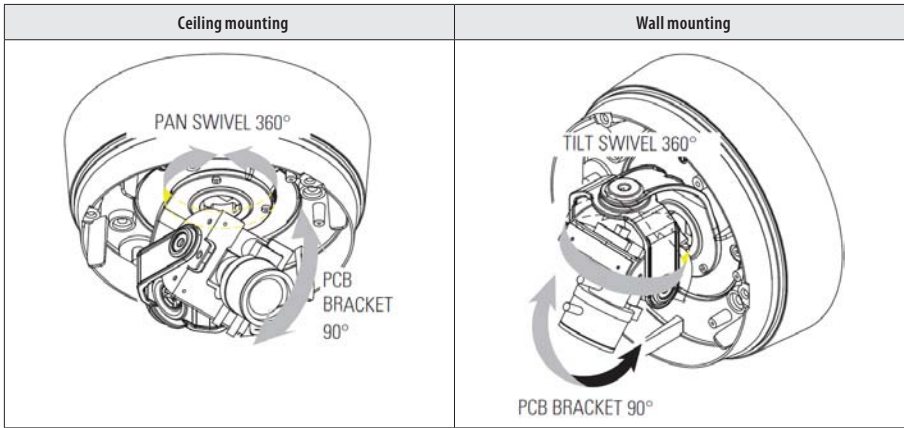

4. Adjust the image with the focus and zoom levers.
5. Configure your camera using the software menus in the OSD. See **Software Setup** in the following section of this manual.
6. Place the dome cover over the base and adjust the dome window. Tighten the captive screws that secure the cover to the base.
7. Clean the camera dome with an approved glass cleaning solution and a lint free cloth.
  - Dust can be removed from the unit by wiping it with a soft damp cloth. To remove stains, gently rub the surface with a soft cloth moistened with a mild detergent solution, then rinse and dry it with a soft cloth.
  - Remove all foreign particles, such as plastic or rubber materials, attached to the camera housing. These may cause damage to the surface over time.



*Do not use benzene, thinner or other chemical products on the camera assembly; these may dissolve the paint and promote damage of the surfaces. Before using any chemical product, read the accompanying instructions carefully.*



## SECTION 3

# Software Setup

Use the SETUP joy stick on the OSD control panel to navigate through the menu system. Press the joy stick down (toward the PC board) to enter the SETUP menu or select an entry, rock the stick up or down to highlight an item in the list, and left or right display the option you want to select.

The SETUP menu consists of a list of sub-menus or displays the option selected for a camera function. When sub-menus are available, the  $\leftarrow$  symbol is shown.

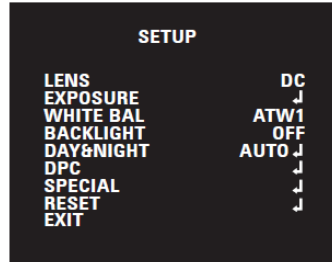

### 3.1 LENS

**LENS:** Select lens type: DC / VIDEO / MANUAL

### 3.2 EXPOSURE

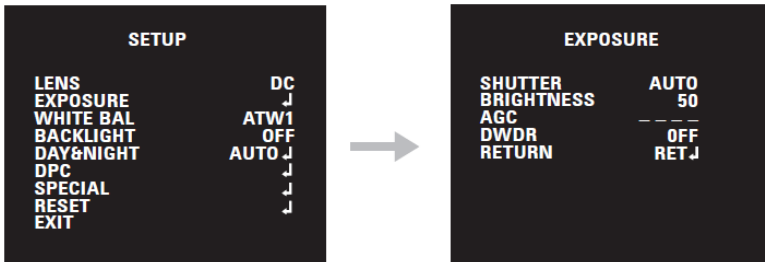

**SHUTTER:** You can set the shutter to auto or manual mode. Options are: AUTO, 1/60 sec, FLK, 1/250 sec, 1/500 sec, 1/1000 sec, 1/2000 sec, 1/4000 sec, 1/5000 sec, 1/10000 sec, 1/100000 sec

**BRIGHTNESS:** You can adjust brightness level. 0 (dark) ~ 255 (bright) steps

**AGC:** You can select auto gain control level. OFF / LOW / MIDDLE / HIGH



## SECTION 3: SOFTWARE SETUP

**DWDR:** The DWDR feature employs intelligent light level control to compensate for strong backlight conditions. DWDR: OFF / ON

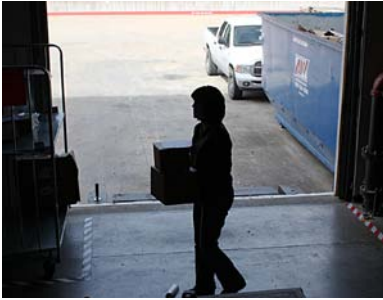

**DWDR OFF**



**DWDR ON**

### 3.3 WHITE BALANCE

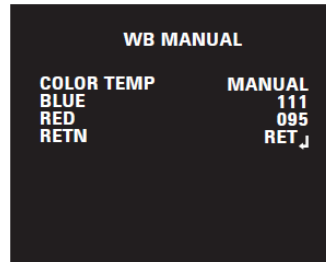
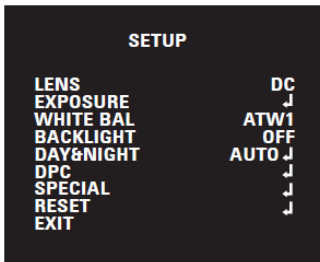

**WHITE BAL:** You can select one of the following modes: ATW1 / ATW2 / AWC → SET / MANUAL (INDOOR / OUTDOOR / MANUAL)

- **ATW1:** Automatically adjusts color according to the available lighting for temperature range: 2500°K to 9500°K.
- **ATW2:** Automatically adjusts color according to the available lighting for temperature range: 2300°K to 10000°K.
- **AWC → SET:** It is a fixed white balance mode that may be automatically readjusted only by pressing SET Button in ONE PUSH mode.
- **OUTDOOR:** Set color temperature for Outdoor light (5400°K)
- **INDOOR:** Set color temperature for Indoor light (3200°K)
- **MANUAL:** Color can be corrected when the user increases or decreases “Red Gain” or “Blue Gain”.
- **RED GAIN:** Adjust R gain value 0 ~ 255
- **BLUE GAIN:** Adjust B gain value 0 ~ 255



### 3.4 BACKLIGHT

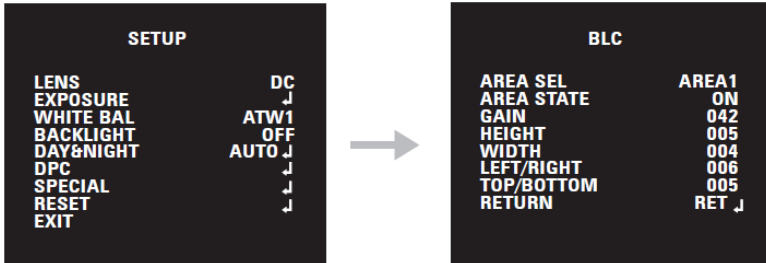

**BACKLIGHT:** Select OFF / BLC / HLC

**BLC** (Back Light Compensation)

- **AREA SEL:** Select AREA1, AREA2
- **AREA STATE:** Select OFF / ON
- **GAIN:** Select 0 ~ 255 steps
- **HEIGHT:** Select 0 ~ 15 steps
- **WIDTH:** Select 0 ~ 15 steps
- **LEFT/RIGHT:** Select 0 ~ 15 steps
- **TOP/BOTTOM:** Select 0 ~ 15 steps

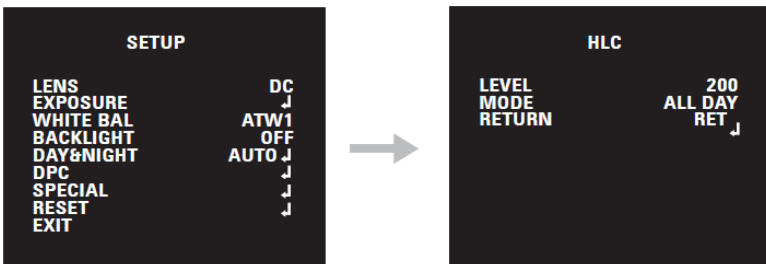

**HLC** (High Light Compensation)

- **LEVEL:** Select 0 ~ 255 steps
- **MODE:** ALL DAY, NIGHT ONLY



### 3.5 DAY&NIGHT

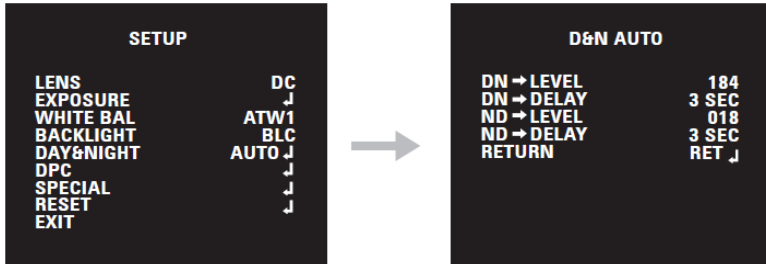

**DAY&NIGHT:** Select AUTO / COLOR / B/W / EXT .

**AUTO:** Day&Night Auto mode

- **D -> N LEVEL:** 182 ~ 192 steps
- **D -> N DELAY:** 1 ~ 30 SEC
- **N -> D LEVEL:** 0 ~ 10 steps
- **N -> D DELAY:** 1 ~ 30 SEC

**COLOR:** Day&Night only color mode

**B/W:** Day&Night black and white (B/W) mode

- **BURST:** OFF / ON
- **IR SMART:** OFF / ON. This option controls the IR LED output level to compensate for object distance. The IR SMART option is used for objects in an area of the image.



**IR SMART OFF**



**IR SMART ON**



**R GAIN:** 0 ~ 255  
**HEIGHT:** 0 ~ 15  
**WIDTH:** 0 ~ 15  
**LEFT/RIGHT:** 0 ~ 15  
**TOP/BOTTOM:** 0 ~ 15

— **IR LEVEL:** HIGH / LOW

**EXT:** Day&Night EXT mode

### 3.6 DPC (Dead Pixel Compensation)



Select DPC for dead pixel compensation processing. DPC can be set to OFF (default) or AUTO. When AUTO is used, the camera will remove defective pixels from an image automatically.

### 3.7 SPECIAL

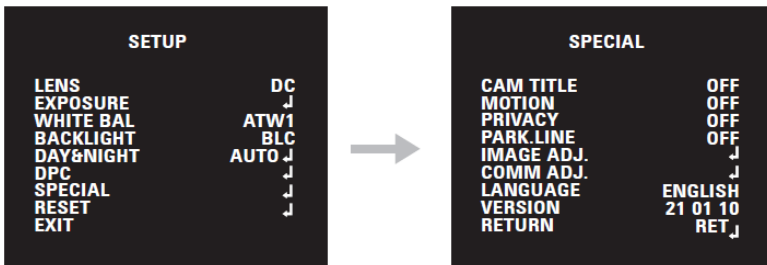

**CAM TITLE:** Select camera title menu (Text edit).



## SECTION 3: SOFTWARE SETUP

**MOTION:** Select camera title menu (Text edit)

- **AREA SEL:** Select AREA1, AREA2, AREA3, AREA4
- **AREA STATE:** Select OFF / ON
- **HEIGHT:** Select 0 ~ 15 steps
- **WIDTH:** Select 0 ~ 15 steps
- **LEFT/RIGHT:** Select 0 ~ 15 steps
- **TOP/BOTTOM:** Select 0 ~ 15 steps
- **DEGREE:** Select 0 ~ 255 steps
- **VIEW:** OFF / ON

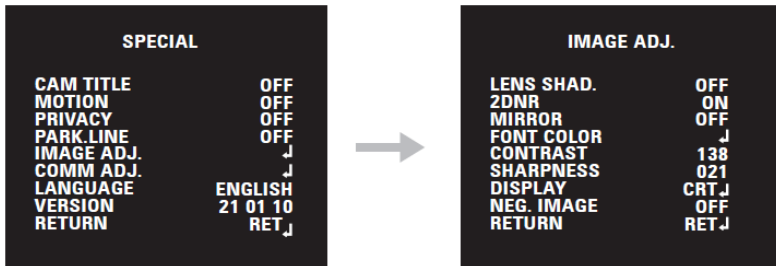

**PRIVACY:** You can cover an area of the screen.

- **AREA SEL:** Select AREA1, AREA2, AREA3, AREA4
- **AREA STATE:** Select OFF / ON
- **HEIGHT:** Select 0 ~ 255 steps
- **WIDTH:** Select 0 ~ 255 steps
- **LEFT/RIGHT:** Select 0 ~ 255 steps
- **TOP/BOTTOM:** Select 0 ~ 255 steps
- **COLOR:** Select 0 ~ 15 steps

**PARK.LINE:** You can insert a line on the screen. This feature may be useful when aligning the camera image with objects in the field of view.

- **LT:** You can adjust the top left area on screen. (0 ~ 195 steps)
- **LB:** You can adjust the bottom left area on screen. (0 ~ 194 steps)
- **RT:** You can adjust the top right area on screen. (0 ~ 194 steps)
- **RB:** You can adjust the bottom right area on screen. (0 ~ 194 steps)
- **F:** You can adjust the front area on screen. (0 ~ 68 steps)
- **N:** You can adjust the near area on screen. (0 ~ 68 steps)



- T: You can adjust the parking line thickness. (0 ~ 15 steps)

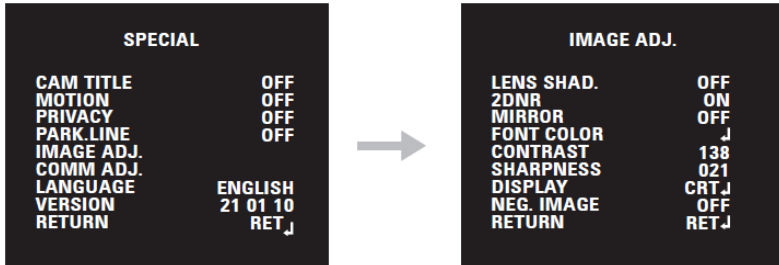

**IMAGE ADJ.:** You can adjust camera image.

- **LENS SHAD.:** LEVEL: 0 ~ 255 steps
- **2DNR:** (on-screen Digital Noise Reduction) (OFF/ON)
- **MIRROR:** (reverse the camera image horizontally) (OFF/ON)

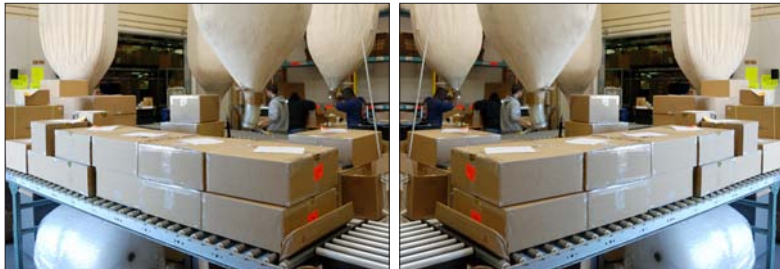

**MIRROR OFF**

**MIRROR ON**

- **FONT COLOR:**
  - FONT:** 16 colors (0 ~ 15 steps)
  - ID & TITLE:** 0 ~ 15 steps
- **CONTRAST:** You can adjust contrast on screen. (0 ~ 255 steps)
- **SHARPNESS:** You can adjust camera image for clarity. (0 ~ 31 steps)
- **DISPLAY:** You can adjust camera output for the display type. (CRT / LCD / USER)
  - CRT (Cathode Ray Tube, Braun tube). PED LEVEL: 0 ~ 63 steps, COLOR GAIN: 0 ~ 255 steps
  - LCD (Liquid Crystal Display)
    - GAMMA: 0.05 ~ 1.00 steps
    - PED LEVEL: 0 ~ 63 steps
    - COLOR GAIN: 0 ~ 255 steps



## SECTION 3: SOFTWARE SETUP

USER

GAMMA: 0.05 ~ 1.00 steps

PED LEVEL: 0 ~ 63 steps

COLOR GAIN: 0 ~ 255 steps

- **NEG.IMAGE:** You can invert a color image, or a black and white image. (OFF/ON)

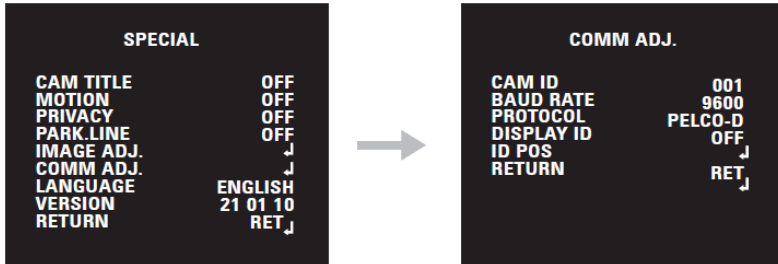

**COMM ADJ.:**

- **CAM ID:** Select the camera ID. 1 ~ 255
- **BAUD RATE:** Select serial communication speed: 2400 / 4800 / 9600 / 19200 / 38400 / 57600 bps
- **PROTOCOL:** Select operating protocol. PELCO-D / PELCO-P
- **DISPLAY ID:** Select display item. OFF/ON
- **ID POS:** You can adjust ID position on screen.

**LANGUAGE:** You can select language. ENGLISH / CHINESE

**VERSION:** Factory vision.

**RESET:** Set the camera options to the factory default settings.



## SECTION 4

# Specifications

**Table 1. Model Differences**

Indoor	Outdoor	TDN	IR
BLK-CCD203VS	BLK-CCD223VS	--	--
BLK-CCD205VH	BLK-CCD225VH	√	--
BLK-CPD206VH	BLK-CPD226VH	√	√

**TDN:** True Day & Night, uses an IR cut filter instead of switching the image to black and white.

**IR:** Built-in infrared LED array

**Table 2. Component Specifications**

Component	Value
Image Sensor	1/3" SONY Super HAD CCD II
Total Pixels	811(H) × 508(V)
Scanning system	2:1 interlace
Scanning frequency	15.734KHz(H), 59.94Hz(V)
Sync system	Internal
Resolution	Max 600 TV lines in color, 650 TV lines in B/W
Min. Illumination	Color: 0.3 lux , BW: 0.1 lux (0 lux @ IR_LED on)
Video output	1.0 Vp-p (75 ohm, composite)
S/N ratio	> 50dB (AGC off)
Exposure	Shutter/Brightness/AGC/DWDR
Lens	DC / VIDEO / MANUAL
Gain control	Off / Low / Middle / High
Shutter speed	1/60 ~ 1/100,000 sec
DWDR	Off / On (0 ~ 35 steps)
Flickerless	Off / On
Brightness	0 ~ 255 steps
White balance	ATW1 / ATW2 / AWC / Outdoor / Indoor / Manual
BLC	Off / BLC / HLC
BLC	Area / gain selectable



## SECTION 4: SPECIFICATIONS

Component	Value
HLC	All Day / Night / (0~255 steps)
Day&Night	Auto / Color / BW / Ext
Auto	Level / Delay selectable
BW	Burst off/on / IR Smart off/on (Gain/level selectable)
DPC	Dead Pixels Compensation
Special	Title / MD / PM / Parking / Image / Comm / Language / Version
Cam Title	Text edit
Motion	Off / On (4 position)
Privacy	Off / On (8 position)
Park. Line	Off / On (variable size)
Language	English / Chinese
Image ADJ	Lens Shad / DNR / Mirror / Font color / Contrast / Sharpness / Display / Neg. Image
Lens Shading	Off / On (0~255 steps)
DNR	Off / On
Mirror	Off / On
Font Color	ID & Title / OSD font color selectable
Contrast	0~255 steps
Sharpness	0~31 steps
Display	CRT / LCD / User
Negative Image	Off / On
Power Source	AC24V / DC12V
Power Consumption	100mA
Power Input	Connector
Video Output	Connector
Operating Temperature	+14°F ~ +122°F (-10°C ~ +50°C)
Operating Humidity	0 ~ 86% (non-condensing)
Storage Temperature	-4°F ~ +140°F (-20°C ~ +60°C)



## APPENDIX A

# Troubleshooting

Problem	Solution
Nothing appears on the screen.	<ul style="list-style-type: none"> <li>- Check the power connections.</li> <li>- Check the video cable connections.</li> <li>- Ensure that the lens mode is set to DC (VIDEO).</li> </ul>
The video image is not clear.	<ul style="list-style-type: none"> <li>- Clean the lens with a soft, clean cloth.</li> <li>- Adjust the monitor screen for room lighting conditions.</li> <li>- Move the camera if necessary.</li> </ul>
The screen is dark.	<ul style="list-style-type: none"> <li>- Adjust the contrast feature of the monitor.</li> <li>- If you have an intermediate device, set the 75Ω /Hi-Z properly, and check the terminals.</li> </ul>
The MOTION DETECTION function is not working	<ul style="list-style-type: none"> <li>- Is "MOTION DETECTION" mode turned on?</li> <li>- Is the MD Sensitivity set too low? Increase the sensitivity.</li> <li>- Check the setting of the MD AREA.</li> </ul>
The WDR function is not working	<ul style="list-style-type: none"> <li>- Is the WDR level too low?</li> <li>- Is the AE Mode set to MANUAL? WDR is disabled in MANUAL exposure mode.</li> </ul>
Colors are not quite right.	<ul style="list-style-type: none"> <li>- Is the camera facing directly into sunlight or fluorescent light?</li> <li>- Is the auto iris lens is being used?</li> <li>- Check the connection of the lens connector cable.</li> </ul>
The Day&Night function doesn't work.	<ul style="list-style-type: none"> <li>- Is the AGC (EXPOSURE menu) set to OFF? The Auto Day&amp;Night Function doesn't work if the AGC is OFF.</li> </ul>



## APPENDIX B Camera Dimensions

### Camera with vandalproof housing

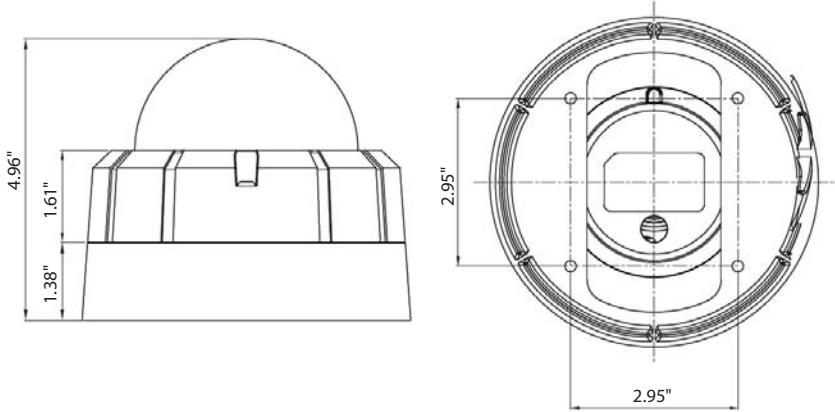

### Camera with plastic housing

