

Interview Room Switch Quick Setup Guide

This setup guide for the Interview Room Switch includes two models: AVSI-SW1 and AVSI-SWF. The AVSI-SW1 is multi-functional device normally used to manually start and stop recording with a DVR. The AVSI-SWF is a fake (faux) switch with an illuminated indicator used to mislead an interviewee into thinking the session is or is not being recorded.



AVSI-SW1



AVSI-SWF

Step 1. Installation – AVSI-SW1, AVSI-SWF

In addition to the switch hardware, this procedure also requires:

- 5/64" hex key
- #1 Phillips screwdriver
- Small slot screwdriver
- Screws and tools for mounting the wall plate
- DC12-500R power supply or equivalent
- Remove the faceplate by removing the two hex screws.
- Cat5 or equivalent signal wire (for AVSI-SW1 only)
- Power extension cable, AVSI-SWF only (to carry 12 VDC @ 100mA)

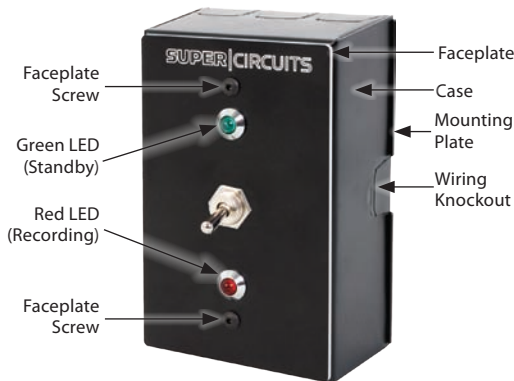

CAUTION Remove the AVSI-SW1 face plate carefully. It is connected to wires that are attached to the mounting plate behind it.

- Remove the two screws securing the case to the mounting plate.

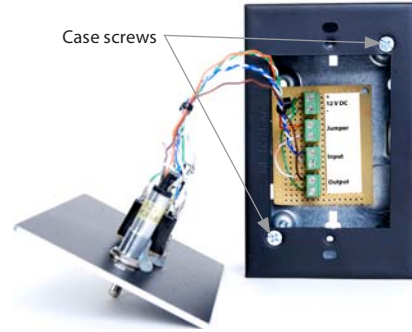

- Determine the path for routing the connecting wires and remove the case or mounting plate knockout as required.
- Anchor the mounting plate to the wall using appropriate hardware.

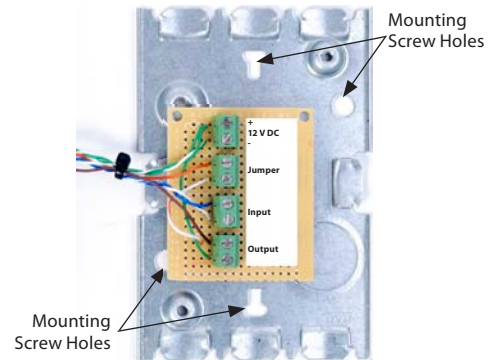

Step 2. Wiring and system checks

AVSI-SW1 only

The AVSI-SW1 contains four 2-terminal connectors. Depending on how these connections are used, the switch can function in different ways:

- **12V DC** – Terminations for 12 VDC power. Apply +12 VDC to the upper terminal (marked "+"), and ground to the lower terminal (marked "-"). +12 VDC power is required to light the LEDs.

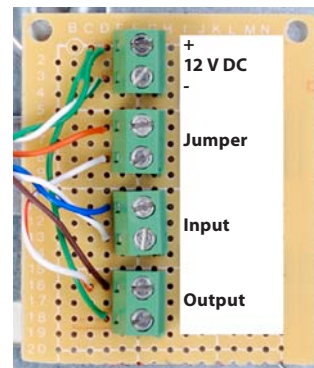

- **Jumper** – A jumper wire placed between these terminals causes the LED associated with the switch position to light. With a jumper in place, the green LED lights if the switch is toggled up, and the red LED lights if the switch is toggled down.
- **Input** – These terminals can be used to manually control a sensor input to a DVR. When the switch is toggled up, the terminals are "open". When the switch is down, the terminals are "closed" (shunted). Usually a DVR sensor input can be configured to control the recording mode of the DVR. These terminals are polarity independent.
- **Output** – These terminals can be wired to the normally open relay output of a DVR for control of the recording indicator (red LED) on the faceplate, independent of the switch position. If used, when the relay output of the DVR is active, the red LED is lit. This connection has no effect on the green LED.

Continue

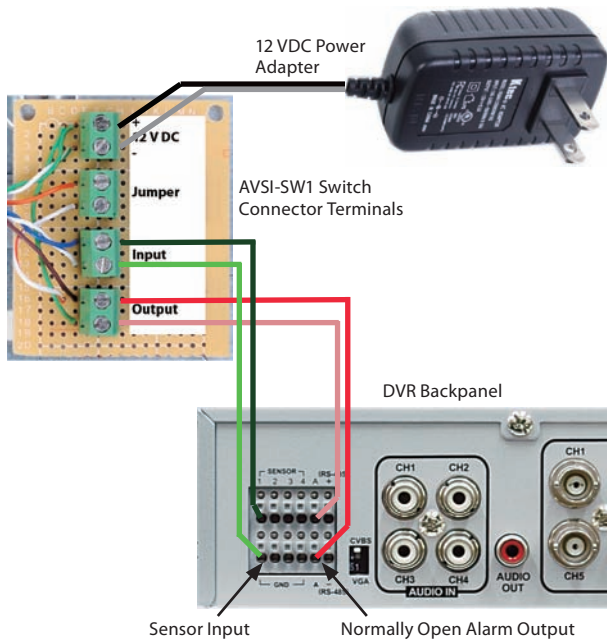

Typical switch - DVR - power interconnections



When connecting wires to the switch, always follow local electrical codes. Cat5 wire is usually sufficient for connecting the switch **Input** and **Output** terminals to the DVR **Sensor input** and **Alarm output** terminals.

- Install a wire loop between the terminals of the Jumper connector, if needed.
- Connect wires between the switch Input and Output connectors and the DVR as needed.
- Trim off excess wire and insulation from the cable.
- Connect the switch 12V DC terminals to a DC12-500R power supply or equivalent. Attach the +12VDC lead to the + (upper) terminal, and the ground lead to the - (lower) terminal. Do not apply power to the power supply at this time.
- Reattach the case to the mounting plate.
- Reattach the face plate to the case.
- Apply power to the power supply.
- Verify that switch LEDs and the toggle switch function as intended.

AVSI-SWF only

- Reattach the case to the mounting plate.
- Route a power extension cable through the switch case and attach it to the power drop on the back of the face plate. The red wire on the power drop is for the V+ (positive, center tap) lead; the black wire is for the V- (negative, barrel) lead.



- Reattach the face plate to the case.
- Attach the other end of the power extension cable to a DC12-500R power supply or equivalent.



Before applying power to the switch, ensure that the voltage polarity at the switch will be correct.

- Apply power to the power supply.
- Verify that one of the LEDs on the switch is lit.
- Turn the key switch to the other position. The other LED should be lit.